

House in SketchUp

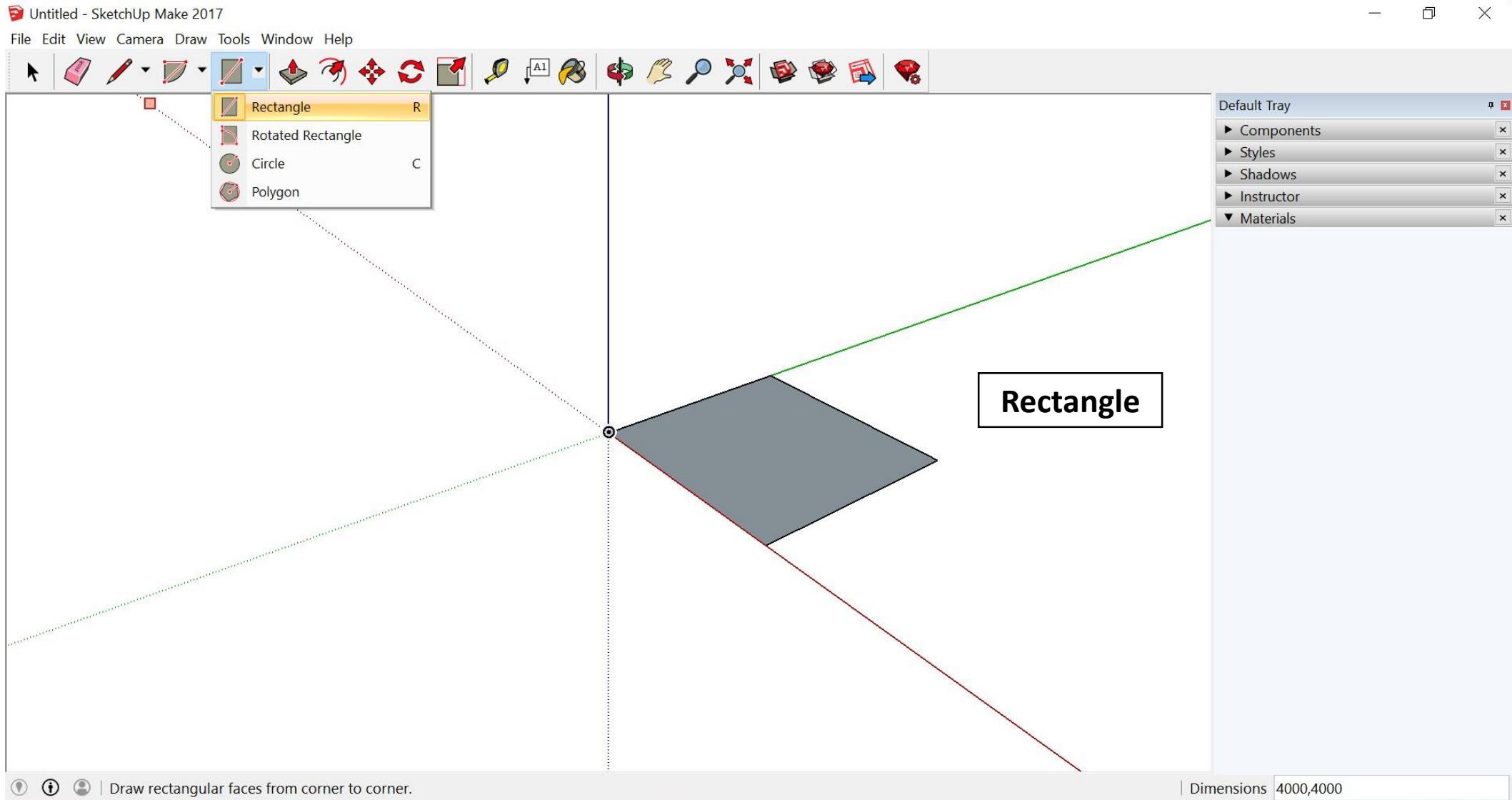

źródło: <https://mastersketchup.com/>





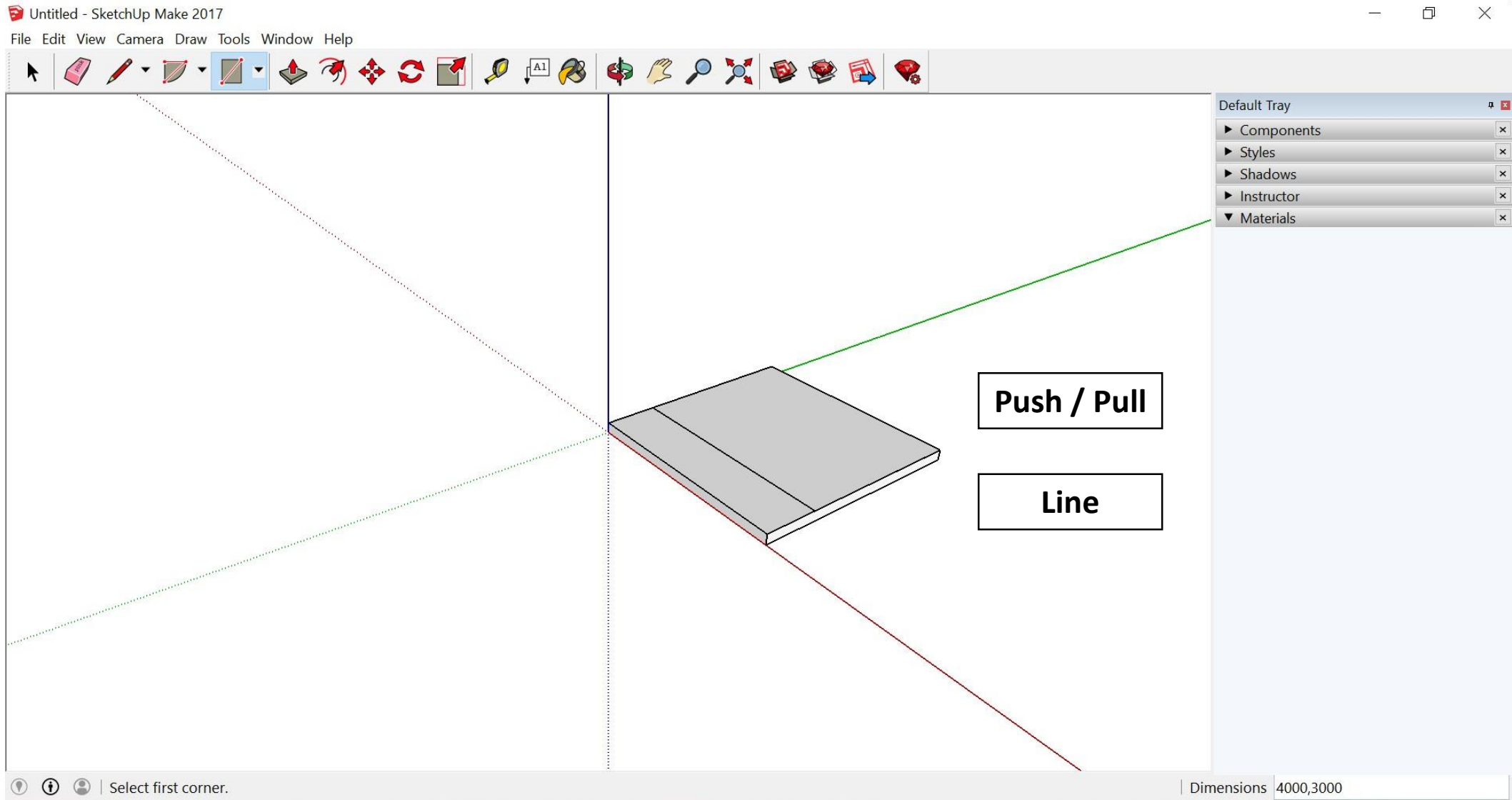

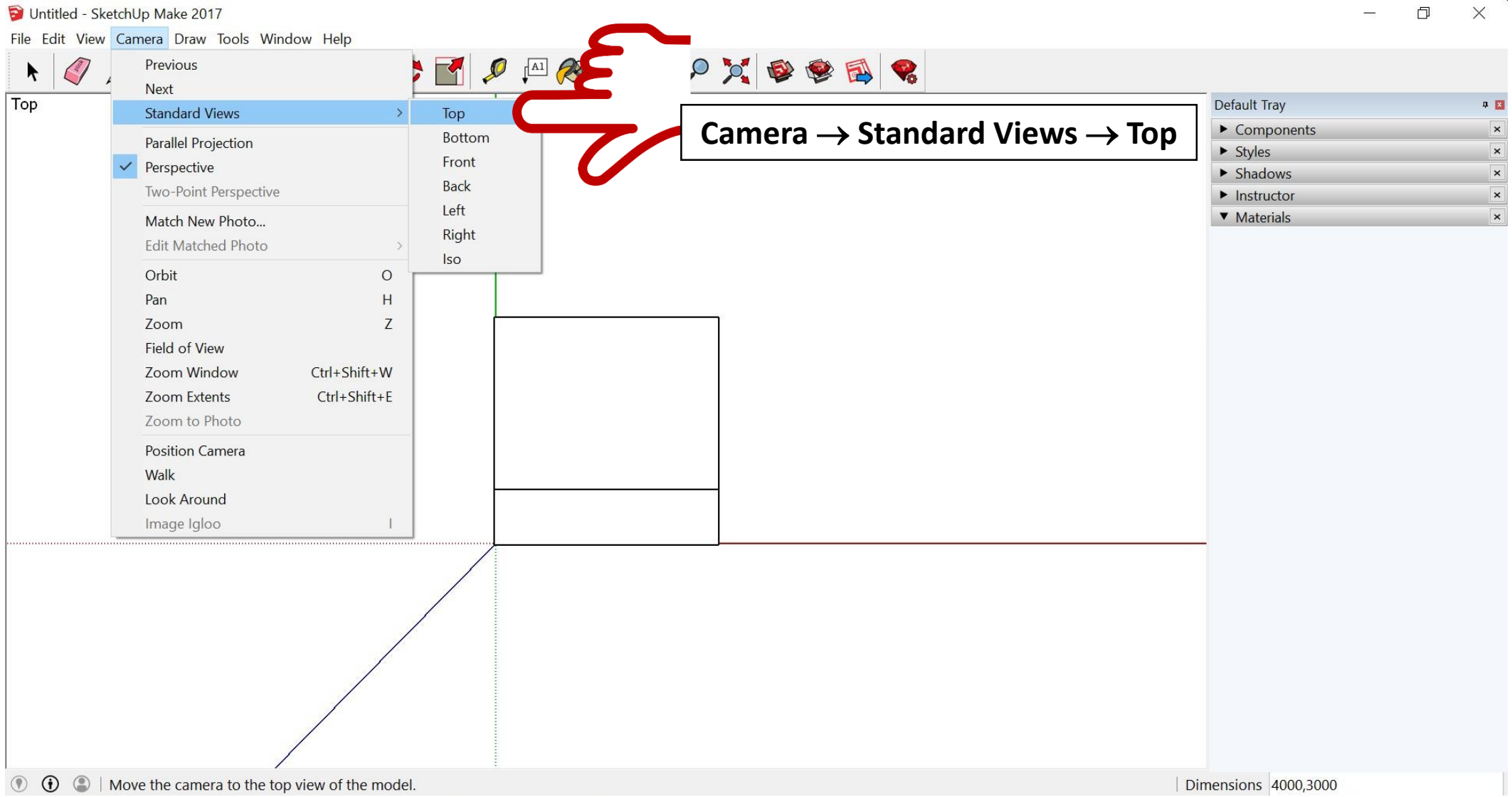

Untitled - SketchUp Make 2017

File Edit View Camera Draw Tools Window Help

Top

Offset

Default Tray

- ▶ Components
- ▶ Styles
- ▶ Shadows
- ▶ Instructor
- ▼ Materials

Distance ~ 124,5mm

Pick point to define offset or enter value. Alt = Allow overlap.

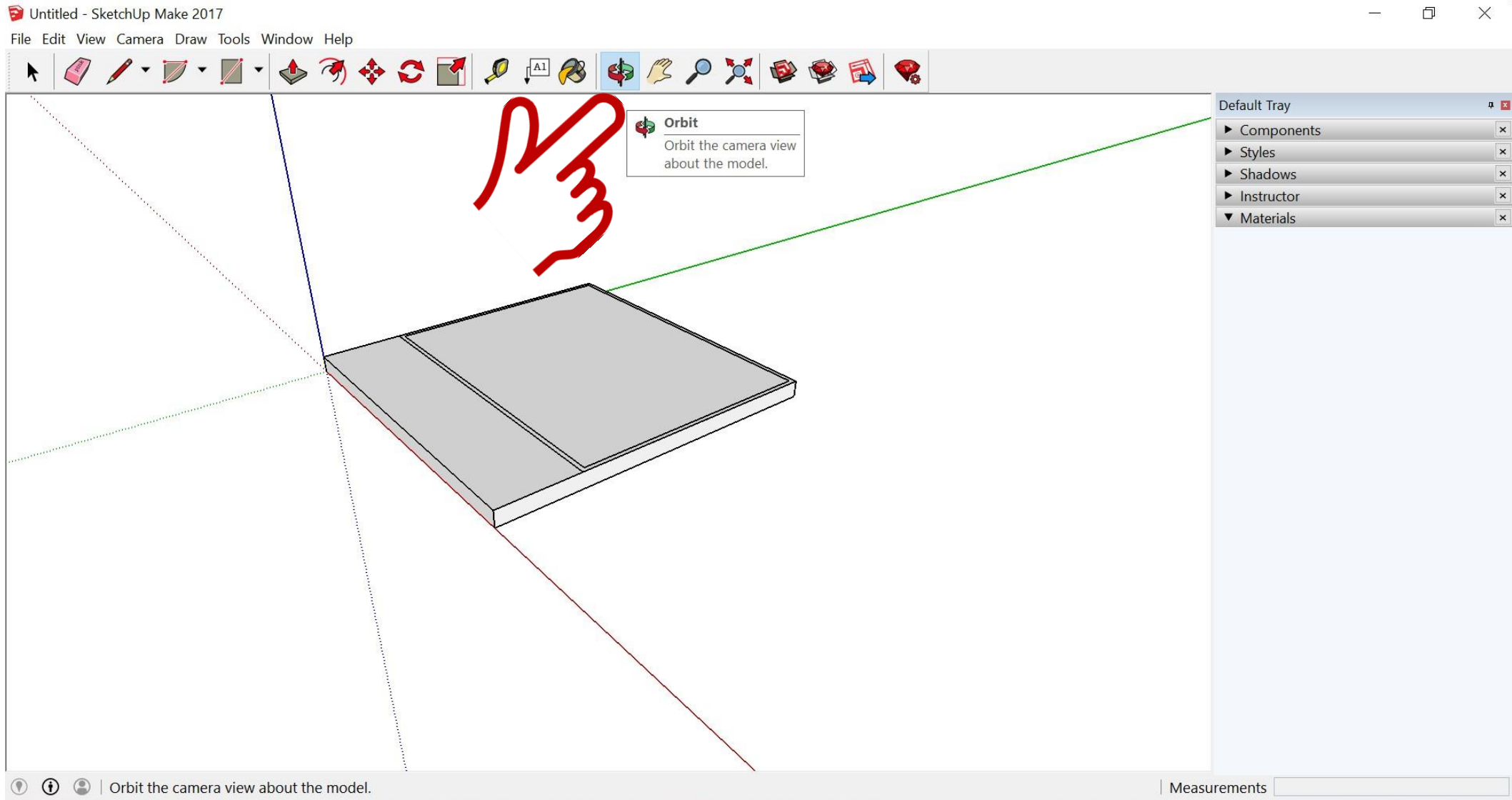

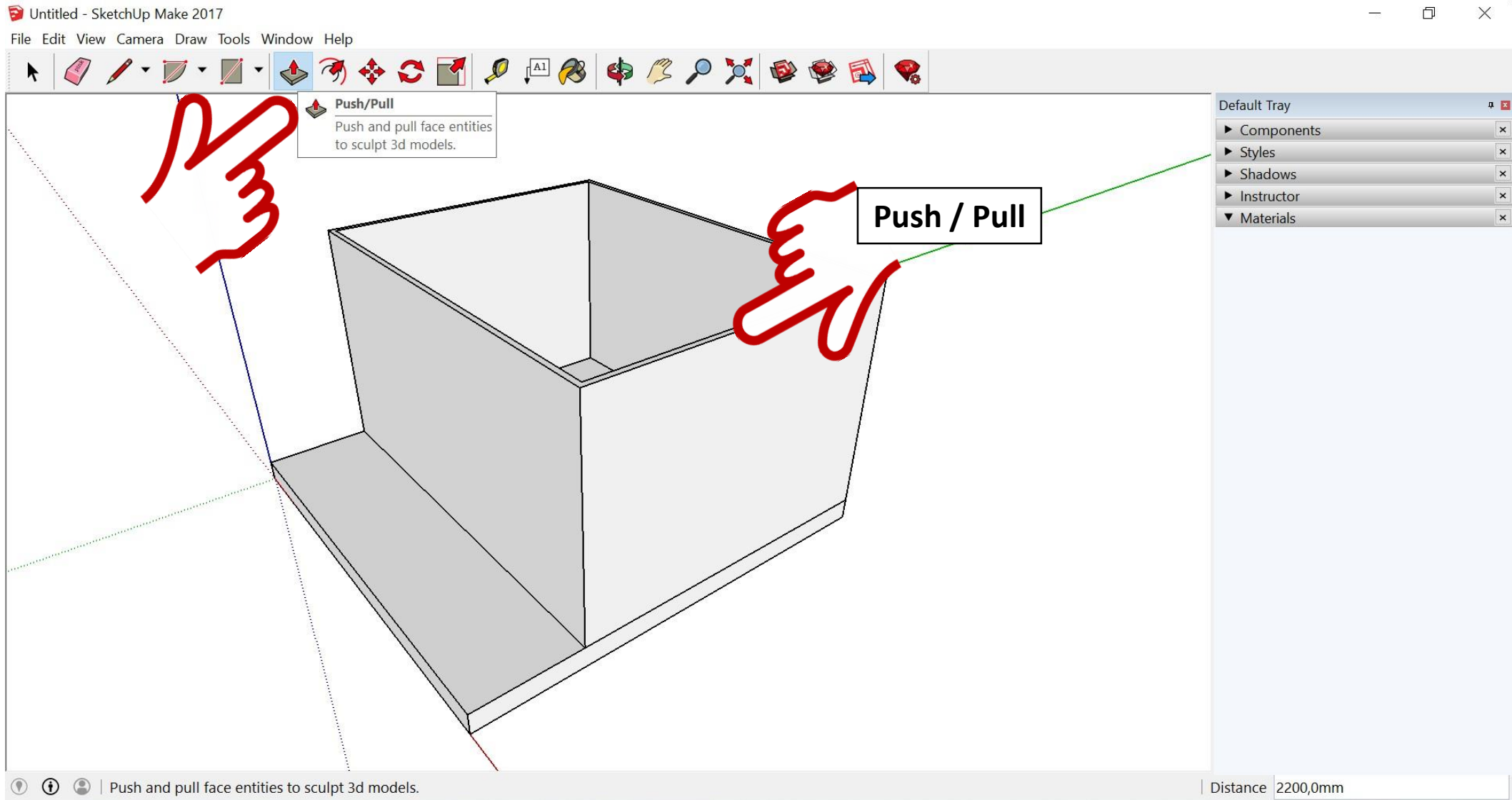

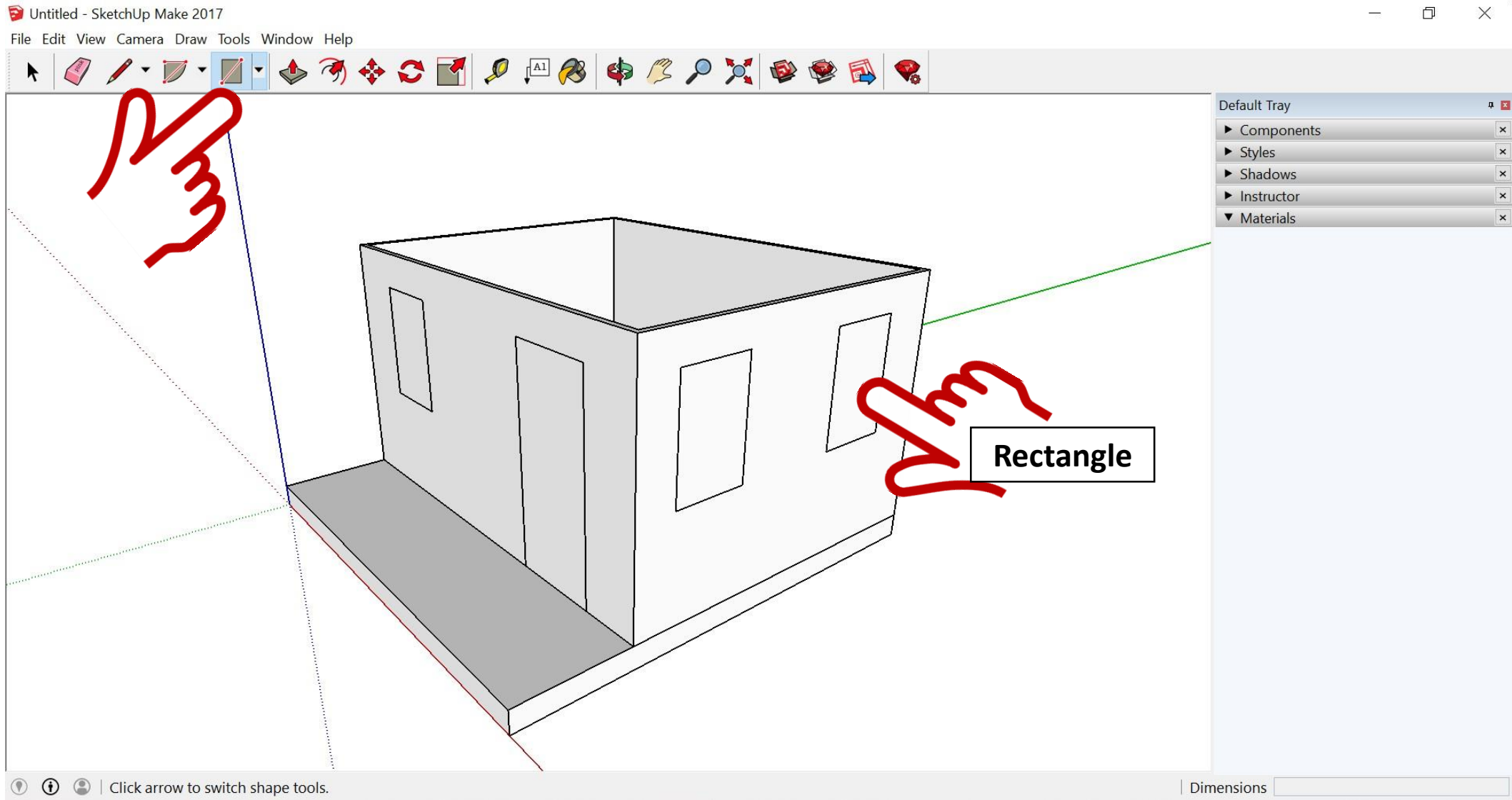

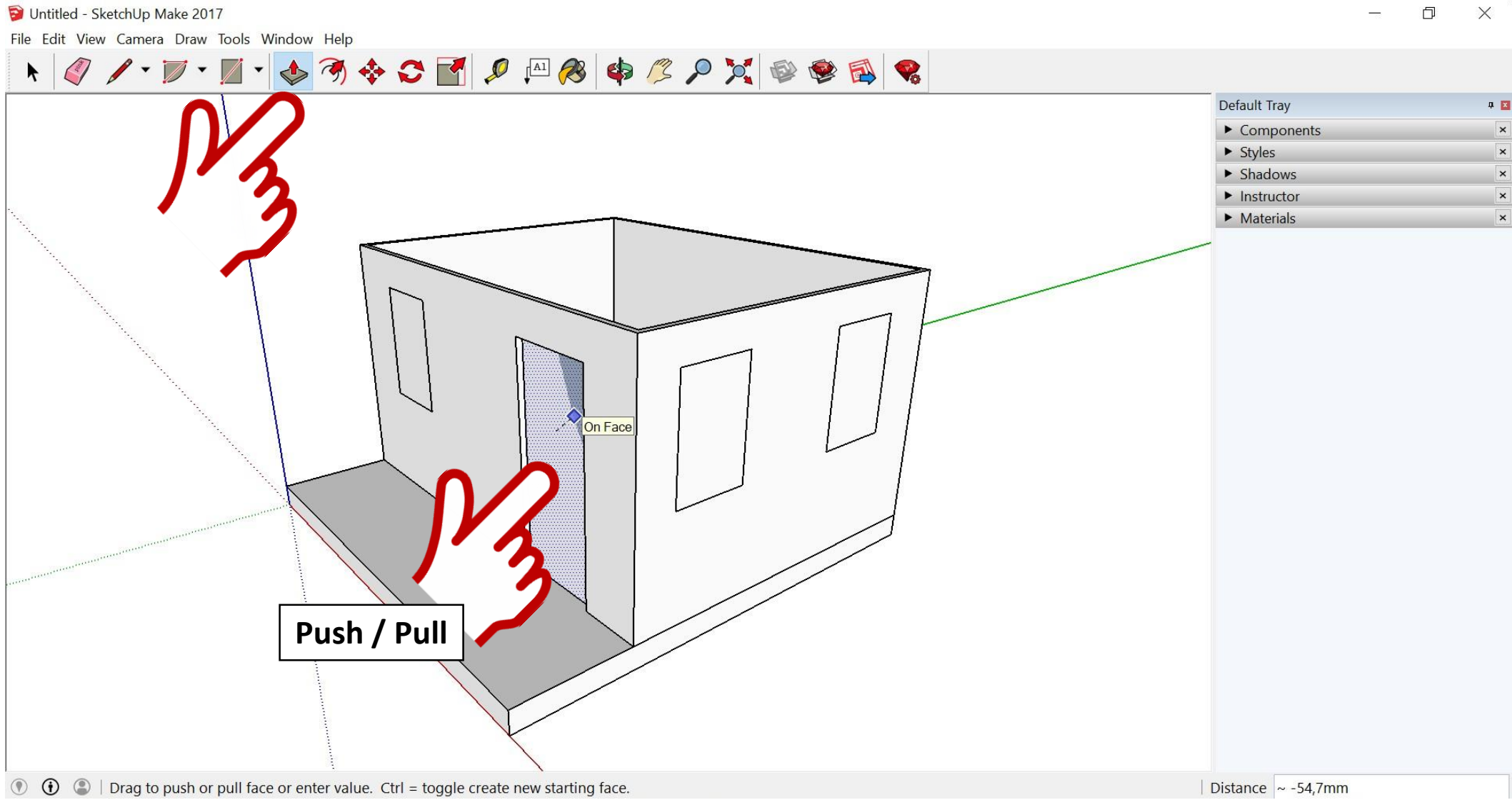

Untitled - SketchUp Make 2017

File Edit View Camera Draw Tools Window Help

Default Tray

- ▶ Components
- ▶ Styles
- ▶ Shadows
- ▶ Instructor
- ▶ Materials

On Face

Push / Pull

Distance ~ -54,7mm

Drag to push or pull face or enter value. Ctrl = toggle create new starting face.

